

A. RODGERS.
Saw-Mills.

No. 152,171.

Patented June 16, 1874.

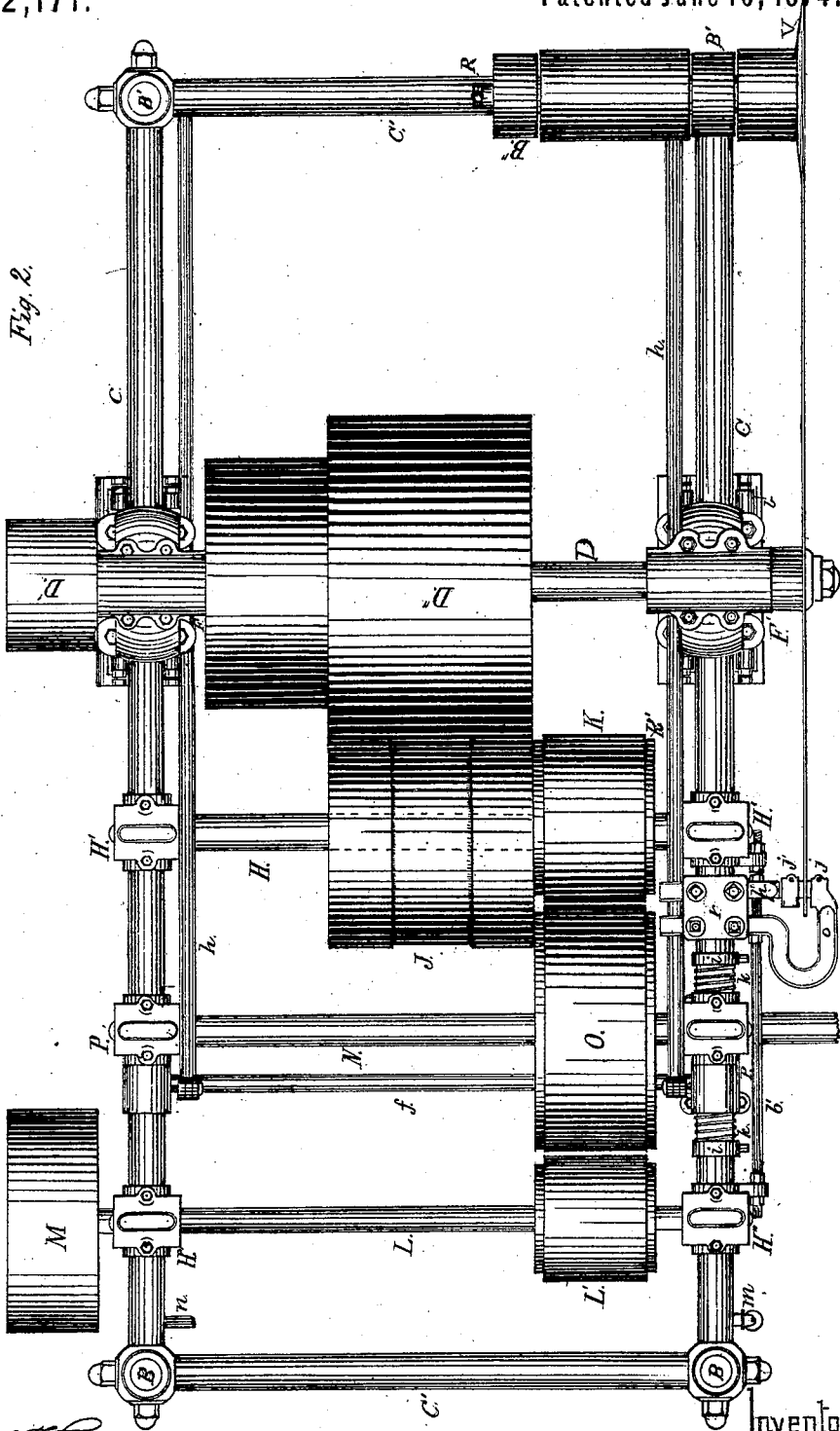

Fig. 2.

Attest. *George M. Howard,*
George M. Howard,

Inventor
Alexander Rodgers
Andrew H. Brown
Atty.

A. RODGERS.
Saw-Mills.

No. 152,171.

Patented June 16, 1874.

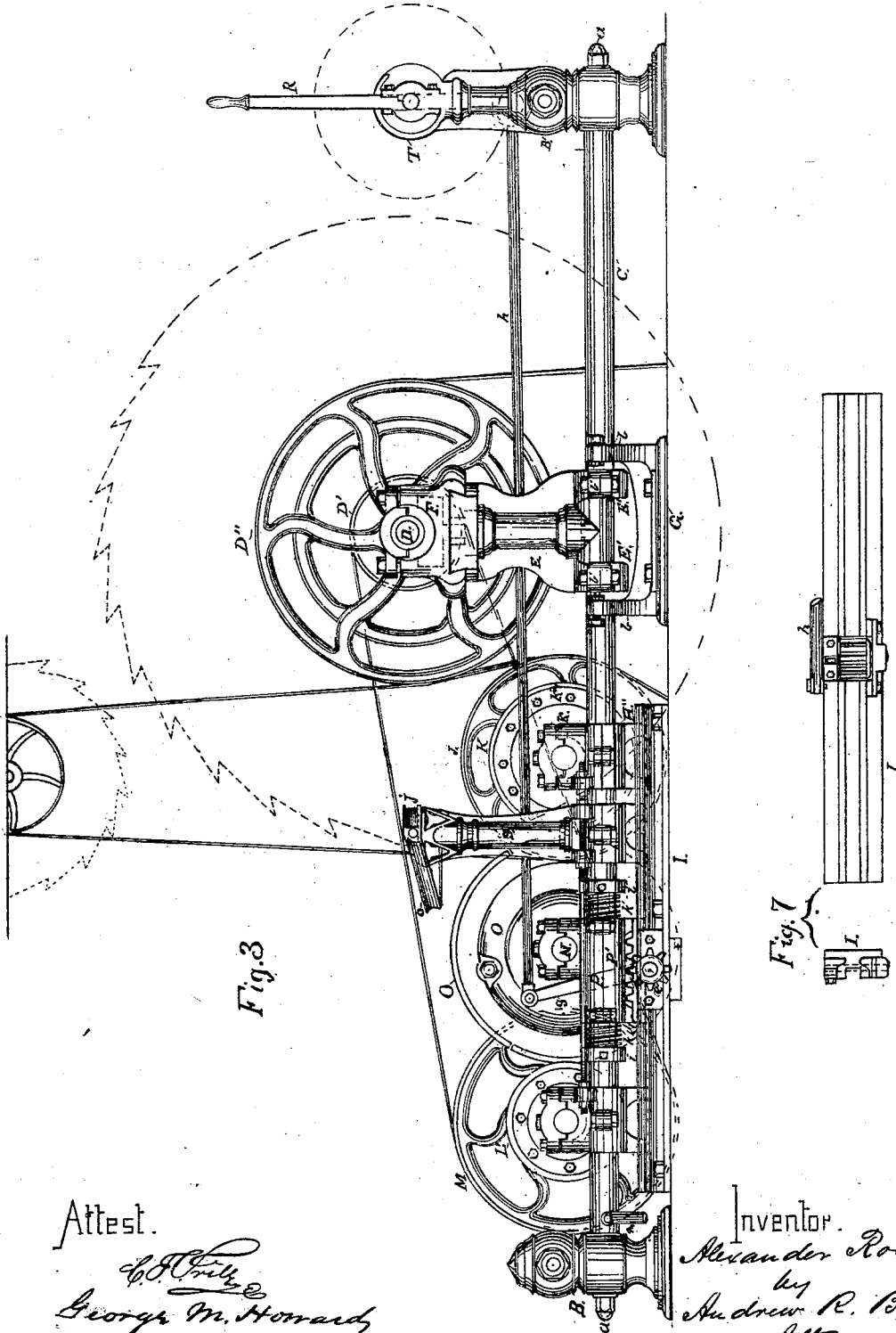

Fig. 3

Fig. 7

Attest.
G. M. Howard
 George M. Howard

Inventor.
 Alexander Rodgers
 by
 Andrew R. Brown
 Atty.

A. RODGERS.
Saw-Mills.

No. 152,171.

Patented June 16, 1874.

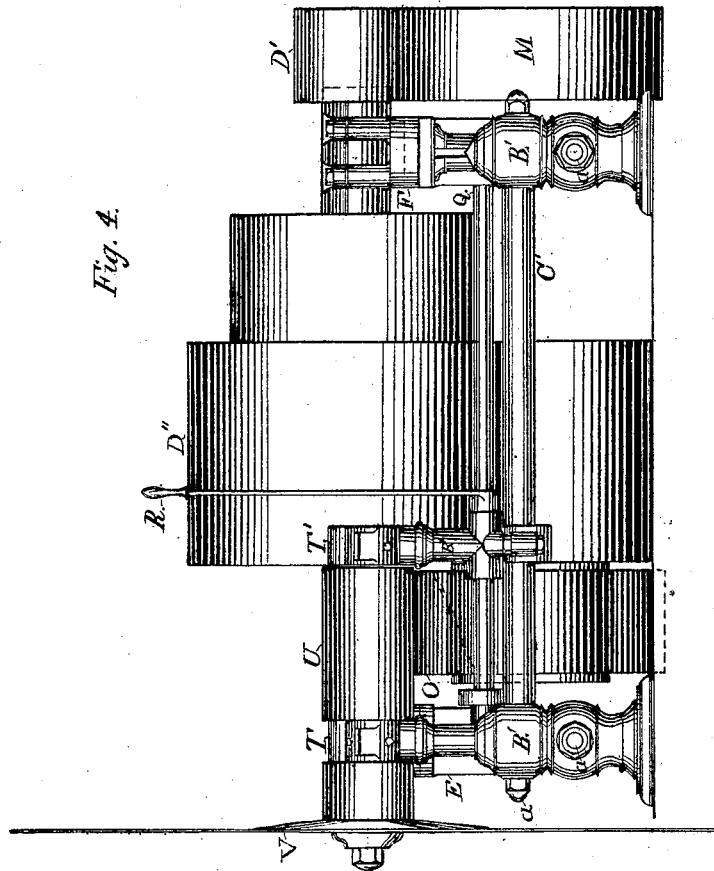

Fig. 4.

Attest.

G. H. [Signature]
George M. Stanton

Inventor.

Alexander Rodgers
by
Andrew R. Brown
Atty.

A. RODGERS.
Saw-Mills.

No. 152,171.

Patented June 16, 1874.

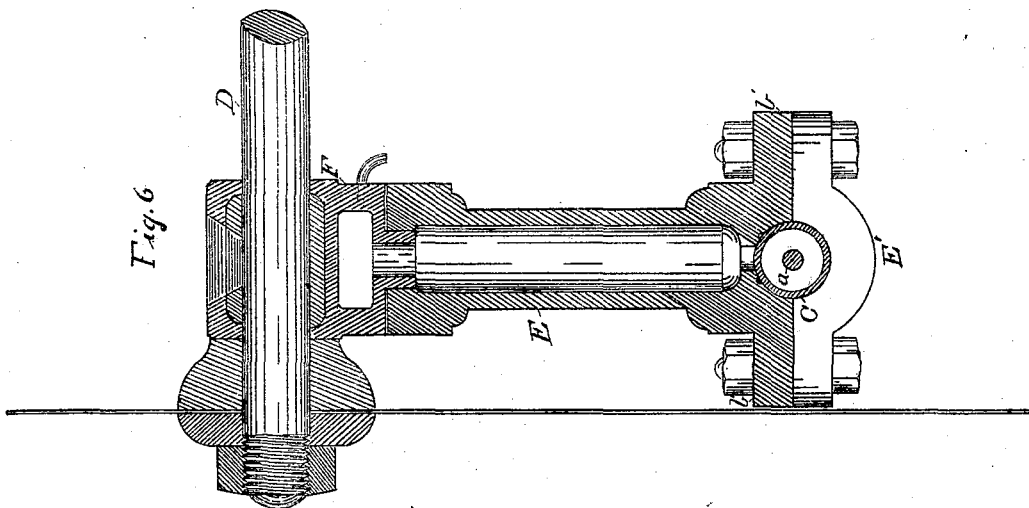

Fig. 6

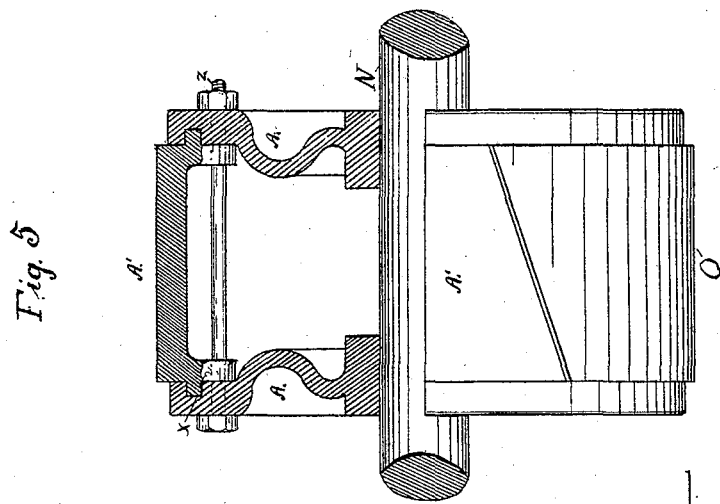

Fig. 5

Attest.

G. M. Howard
George M. Howard,

Inventor.

Alexander Rodgers
 by
Andrew R. Brown
Atty.

A. RODGERS.
Saw-Mills.

No. 152,171.

Patented June 16, 1874.

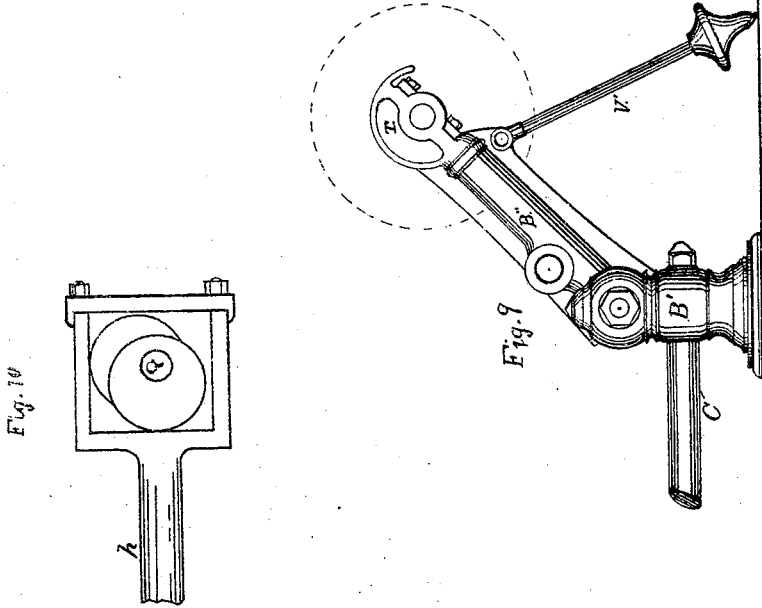

Fig. 10

Fig. 9

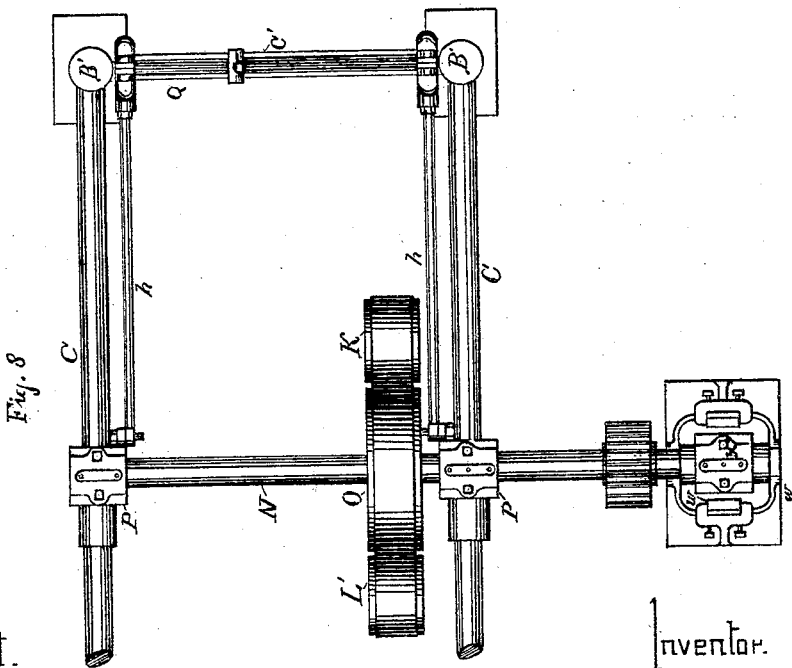

Fig. 8

Attest.

G. P. [Signature]
George M. Howard

Inventor.

Alexander Rodgers
by
Andrew R. Brown
Atty.

A. RODGERS.
Saw-Mills.

No. 152,171.

Patented June 16, 1874.

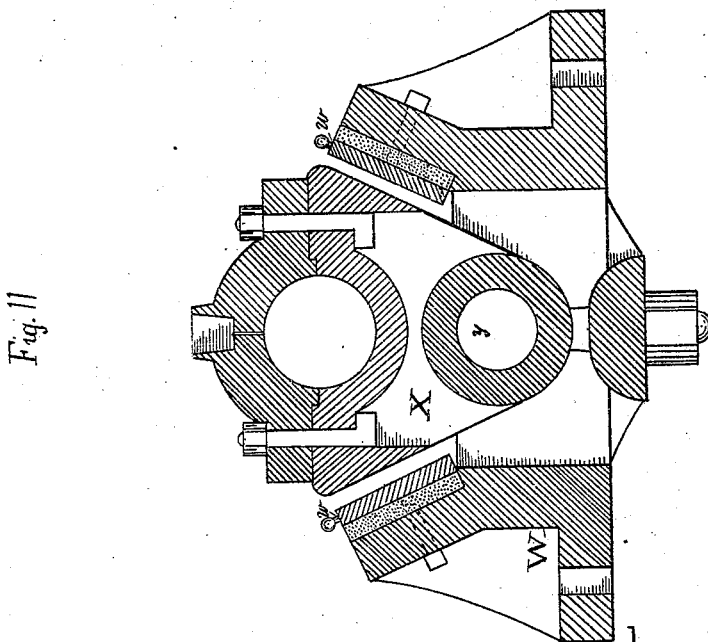
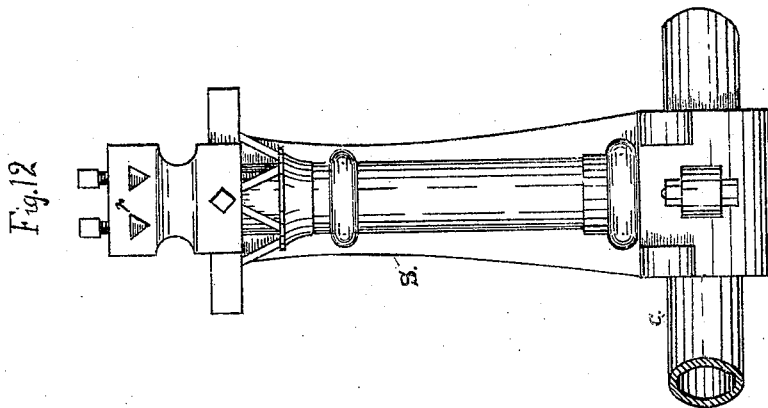

Attest.

C. H. Smith
George M. Howard,

Inventor.

Alexander Rodgers
by
Andrew R. Brown
Atty.

UNITED STATES PATENT OFFICE.

ALEXANDER RODGERS, OF MUSKEGON, MICHIGAN.

IMPROVEMENT IN SAW-MILLS.

Specification forming part of Letters Patent No. **152,171**, dated June 16, 1874; application filed June 1, 1874.

To all whom it may concern:

Be it known that I, ALEXANDER RODGERS, of Muskegon, in the county of Muskegon and State of Michigan, have invented certain new and useful Improvements in Saw-Mills; and I do hereby declare the following to be a full, clear, and exact description of the invention, such as will enable others skilled in the art to which it pertains to make and use it, reference being had to the accompanying drawings, which form part of this specification.

The object of this invention is to furnish the lumber manufacturer with a machine for sawing logs into lumber, which possesses improvements in its construction by which certain advantages are gained in points of durability and special arrangement of parts, so as to obtain easy access to them, as well as keeping them of an even temperature, by which the amount of lumber which can be cut in a certain specified time over other similar machines using an equal amount of power, is considerably increased, from the fact that it has heretofore been found almost impossible to run circular saws of large size in cutting lumber from the log without heating the journals of the saw-arbor to such an extent as to cause frequent stoppages of the mill necessary for the purpose of cooling the same.

Many devices have been invented for the purpose of obviating this difficulty, such as allowing the saw-arbor to have end play in the journal-boxes, with various compositions styled anti-friction metals, and allowing a stream of water to fall upon the boxes, all of which proved to be of doubtful efficacy, except the last; and although this has proved a success, so far as to keep the parts cool, it was found impracticable, as the spray kept everything in the vicinity wet and dirty, as well as causing the frictional surface of the feeding apparatus to slip upon each other, thus producing irregularity in the movement of the log-carriage, and a consequent diminution in the quantity of lumber cut, as well as causing great wear and strain upon the different parts of the machine.

The means which I employ for obviating the difficulties above enumerated, as well as others which have heretofore been encountered in the construction and operation of this class of machines, consists, first, in forming the

frame of the machine hollow, so as to allow a stream of cold water to circulate through all its parts, as well as through the several journal-boxes; secondly, in the method of attaching the principal journal-boxes to the frame; thirdly, in the means employed for the purpose of rendering the friction-wheels less liable to fracture from the sudden expansion of a part from the heat engendered by the continued pressure and movement of a driving friction-pulley upon any portion of its surface, and, fourthly, in certain details of construction, which will be hereinafter fully described and claimed.

In the accompanying drawings, similar letters of reference indicate corresponding parts in the different figures.

Figure 1 is a perspective view of the machine complete. Fig. 2 presents a vertical plan view, showing the arrangement of the different parts of the mechanism. Fig. 3 is a side view, and illustrates the method of constructing and bracing the frame, as well as the position occupied by the upper saw, when one is used, with relation to the other parts of the machine. Fig. 4 is an end view of the machine, showing the position of the operating-lever. Fig. 5 is a sectional view of the friction-pulley upon the feed-shaft. Fig. 6 is a vertical section through one of the columns and journal-boxes, which support the saw-arbor. Fig. 7 presents a plan and section of the bed used for the purpose of retaining different parts of the machine in a vertical position. Fig. 8 is a plan of a portion of the frame, showing the arrangement of the boxes for supporting the feed-shaft, together with a modification of the means employed for operating them. Fig. 9 is a detached view of the splitting-wheel and its supporting mechanism. Fig. 10 represents the cam or double eccentric, by which the feed-shaft may be moved in order to bring the friction-pulley by which it is revolved, into contact with the feeding and gigging pulleys. Fig. 11 is an enlarged sectional view of the oscillating journal-box, which supports the outer end of the feed-shaft. Fig. 12 shows the device by which the saw-guides are adjusted upon the top of the supporting-column to suit saws of different diameters.

The frame is constructed of a series of stand-

ards, B and B', which are cast hollow, and provided with suitable openings for the reception of the ends of the metal pipes C and C', which enter into and are firmly secured therein by means of the rods a, which are provided with a screw-thread and nut at each end, and pass through both the pipes and standards. It will thus be apparent that when the ends of the pipes are inserted in their appropriate orifices in the standards, the rods passed through, and the nuts firmly screwed up, a rectangular frame is formed, combining as great an amount of strength and stiffness as our knowledge of the laws of physics enables us to produce from a certain amount of material, and this frame forms the basis upon which the superstructure we are about to describe is erected. The saw-arbor D is carried upon the hollow columns E E. These are formed at their base with a semicircular concavity, which embraces the upper half of the pipes C, and are further provided with projecting lugs upon each side, to which are bolted the caps E'. A small opening is made in the pipes C, which connects with the cavity in the columns, a channel being formed around the opening in the base of the column for the reception of a rubber packing-ring or its equivalent, which, when the parts are secured in position, forms a water-tight joint around the openings in the pipe. The top of the columns forms a circular dovetail, upon which the journal-boxes F are secured, and move in ranging the saw. These journal-boxes are cast hollow, and provided with an orifice opening into the cavity of the columns. It will be seen that the base of the boxes forms a female dovetail, into which the head of the column enters, and in order to accomplish this result they are both formed as sections of a circle, so that, when the box is placed at right angles to its proper position, and guided by a central pin, it will drop over the head of the column, and then, upon being turned one-fourth of a complete revolution, is firmly fastened to the column, upon the top of which is placed a thin sheet of rubber or other analogous elastic substance, for the purpose of relieving the machine from the jar and shock arising from the action of the saws upon the log, or any inequalities in the thickness of the driving-belt, as well as to keep the joint between the column and box water-tight. The saw-arbor D is made, preferably, of steel, and is provided at one end with suitable collars for holding the saw, and at the opposite end with a pulley, D', upon which runs the belt that gives motion to the feeding devices, and near the middle is secured the main driving-pulley D'' of the machine, which is revolved by a belt from a pulley driven by any suitable motor, and between these two pulleys is one which may be used for driving an upper saw, if desired. Secured to the floor of the mill, beneath the pipes C where they support the columns E, are the bearing-plates G. These plates are provided with lugs b, through which pass temper-screws,

bearing against the lugs b' at the base of the columns.

It will be evident that, by means of these temper-screws, the columns carrying the saw-arbor may be moved upon the pipes C, thus giving, or, as it is technically termed, ranging, the saw such inclination with the line of cut as may be desired, the construction of the journal-boxes allowing such movement without causing any tendency of the arbor to bind in the boxes. Immediately in front of the saw-arbor, and parallel therewith, is the shaft H, running in journal-boxes H', which are constructed with hollow spaces, having an opening into the pipes C through an orifice surrounded by a rubber gasket, in a similar manner to that opening into the columns E, and they are secured upon the pipes C by means of a cap, H'', upon the under side of the pipe, to which they are bolted. Forming a part of this cap are two downwardly-projecting lugs, which enter a longitudinal groove in the bed-plate I that is secured to the floor of the mill, and serves the double purpose of keeping the journal-boxes of the shafts carrying the feeding and gigging friction-wheels in a perpendicular position, as well as forming a support for the rock-shaft and pinion, which moves the journal-box of the feed-shaft. Upon this feed-shaft H is secured the pulley J, which is put in motion by the main driving-belt of the machine, against which it bears. Upon the same shaft, and adjoining this pulley, is secured the friction-wheel K, which is formed by placing upon a central hub rings of paper, pasteboard, or similar material, they being held in position by a follower, K', secured to the hub by means of several bolts, which pass through the follower and rings and into the hub, after which the whole is placed in a lathe, and the outer surface turned off smooth. The shaft L is provided with a friction-wheel, L', of similar construction, but of less diameter. It also runs in journal-boxes H'', identical in construction with those which carry the shaft H. Motion is imparted to this shaft L by a belt running upon the pulley D, and around the pulley M upon the end of the shaft L. Occupying an intermediate position between the friction-wheels L' and K is the friction-pulley O, secured to the feed-shaft N, which is journaled upon the frame in the reciprocating bearings P. This pulley O is so constructed as to avoid the frequent loss of time in repairing, and the stoppage of machinery which occurs through the breaking of the metallic friction-wheels commonly used in this class of gearing, by the unequal expansion of its different parts, owing to the heat developed by the frictional surfaces slipping one upon the other. This slipping is of frequent occurrence in the feed-gearing of saw-mills, and, owing to the peculiar nature of the work, is unavoidable, it being a common practice with sawyers when a very large and heavy log is upon the carriage, through which it becomes difficult to force the saw, to allow the

feeding-friction to slip occasionally in order that the saw may clear itself and regain its impetus.

A A, Fig. 5, are two side pieces or disks, cast in the corrugated form shown, or they may, in the case of large wheels, be formed with arms similar to those commonly used for large pulleys. Near their periphery is a circumferential groove, *a*, for the reception of a tongue, which forms a part of the segmental friction-plates A'. These plates are further secured to the side pieces by means of the bolts *z* passing through the side pieces, and through the lugs which project inward from the plates A'. It will be apparent that the number of these friction-plates must depend upon the size of the wheel in which they are fixed. The ends of the different pieces are cut diagonally, so that the bearing of each wheel upon its fellow is continuous, no difficulty being experienced from the slight open spaces at the joints, no matter what number of segmental plates are employed.

This method of construction enables the manufacturer to use cast-iron, which is of small cost, for the sides of his wheel, while gun-metal, or any other suitable alloy of metals, of greater cost but more durable, may form the wearing-surfaces, thus saving the expense of a wheel formed wholly of the more costly metal, while all its advantages are retained.

To the reciprocating bearings P are secured caps F' by suitable bolts. These caps are provided with a downwardly-projecting flange, which enters the groove in the bed-plate I, and has formed upon one side the rack *d*, (seen in Fig. 3,) in which meshes the pinions *e* upon the rack-shaft *f*, (seen in Fig. 2.) Attached to this shaft is one or more upright arms, *g*, to the upper ends of which are pivoted the rod or rods *h*, the opposite ends of these rods being attached to an eccentric upon or to an arm of the rack-shaft Q, which is journaled in the standards B', and near its middle is fixed the hand-lever R. In Fig. 10 is shown a double eccentric or cam, having the form of two eccentrics placed at right angles to each other, thus giving double the throw from the same movement, of the hand-lever as would be secured from a single one of the same kind. It will be apparent that any movement of this hand-lever from the perpendicular must, through the connecting mechanism, carry the journal-boxes P, and with them the feed-shaft and friction-pulley O, toward one or the other of the wheels L' K; and, if the movement is continued, the pulley O will engage with one of them, and impart its motion to the log-carriage of the mill through the pinion upon the outer end of the shaft N. This end of the shaft rests in a journal-box, clearly shown in Figs. 8 and 11, in which W represents the bed, cast with an opening through it, in which is inserted the oscillating box X, through the lower part of which passes the shaft *y*, the ends of which are held firmly

in position by eyebolts passing downward through the bed W. Attached to this bed, upon either side of the oscillating box, by means of screw-bolts passing through slots in the bed, are two bearing-plates, *w*, each resting upon an elastic cushion of rubber or other suitable material, and forming the end support of the box as it is thrown from side to side by the movement of the feed-shaft in operating the mill.

It will be observed that this device enables the feed-shaft to preserve its parallelism with relation to shafts carrying the feeding and gigning pulleys, an arrangement which will be found to possess great advantages, as by its means the faces of the different friction-pulleys are always in the same line, giving an equal pressure over their whole breadth, thus preventing their slipping upon each other, and causing the wear to be equalized across the entire face, thus rendering them much more durable than in machines which do not maintain their shafts in parallelism.

When an upper saw is to be attached to the machine, it may be operated by a belt running in a recess in the surface of the pulley J, which is formed of such depth as to receive it; and it thus receives motion not only from the pulley, but, from its contact with the main driving-belt of the machine, as shown in Fig. 3.

By this arrangement the series of guide-pulleys required to change the direction when the saw is driven directly from the main arbor is dispensed with, and a much cheaper and more compact arrangement substituted. Two collars, *i i*, are adjustably secured upon the pipe C, upon opposite sides of the journal-boxes P, leaving a sufficient distance between them and the box for the insertion of the springs *k k*, which are preferably made of steel wire wound around the pipe. It will be seen that these springs, acting upon the opposite ends of the journal-box, tend to return it to and hold it in one position when moved from that point in either direction, thus holding the friction-pulley O in a central position between the wheels L' and K, except when forced out of it by means of the hand-lever R, and the intervening mechanism connected therewith. This arrangement is found to be of great service, as by it the frictional surfaces are kept from touching each other, except when in actual use, thus preventing their destruction by the heat which is engendered, when they are allowed to remain in contact with each other without revolving simultaneously. Another column, S, is placed upon the pipe C, between the journal-boxes P and H', being secured to it and retained in a vertical position by the same means which are used for the purpose of retaining them upon the pipe. This column carries the saw-guides, which are formed of two bars, *o p*, triangular in section, and the bar *o* having a U-shaped curve forming a loop through which the teeth of the saw pass. They are both adjustably secured to the top of the column S by means

of a plate, *r*, and set-screws, which force them into triangular grooves formed in the movable plate which is secured to the top of the column, as seen in Fig. 12. The ends *j* and *j'* of these guides are each provided with a pair of jaws, the lower one of which is pivoted, and near their extremities is a bolt passing through both, by which they are caused to hold firmly the material used for the actual bearing and guiding surfaces of the saw, and which may consist of pieces of wood, layers of rawhide, leather, paper or such other material as the operator of the machine may consider most useful for the purpose. Upon the journal-boxes *H'* and *H''*, and the column *S*, are formed lugs, through which pass the stiffening-bars *b''*, having screw-threads cut upon them in such positions as to allow the nuts placed thereon to be screwed up firmly on opposite sides of the lugs, thus binding the whole together, and holding each part in its allotted position. Upon the top of the standards *B'* and *B''* are formed the hooded journal-boxes *T* and *T'*, which carry the roll *U*, upon the outer end of which is secured the splitting-wheel *V*.

These devices may be fixed in one position, or rendered adjustable by means of the support *V'*, as shown in Fig. 9. It will be observed that this method of forming the journal-boxes enables them to present a smooth unbroken curve upon the side next the saw, as well as preventing the entrance of extraneous matters through the oil-cup to the journal. Two pipes, *m* and *n*, are attached to the side pipes *C* *C*, or other suitable part of the frame, one being for the entrance and the other for the exit of a stream of water, which it will be seen must pass through all parts of the frame, as well as through the different journal-boxes and their supports before leaving the machine, reaching the journal at the outer end of the feed-shaft through a tubular opening therein, which may receive its water through orifices in one of the bearings *P*, or by a connection at either end, thus carrying off all the heat caused by the friction of the journals, and keeping the whole mechanism at an equable temperature.

It will be evident that, where it is inconvenient to allow the flow of water through the machine, solid bars may be substituted for the pipes without in any way changing the general construction and arrangement of parts, but the pipes are preferred. The operation of this machine does not differ materially from those now in use, in which the log to be cut into lumber is placed upon a suitable carriage provided with guiding-wheels, and running upon a track of proper construction, the carriage being also provided with a rack into which gears the pinion upon the shaft *N*, thus enabling the operator to give to the carriage a reciprocating movement through the series of devices heretofore described.

Having thus described my invention, I claim as new and desire to secure by Letters Patent the following:

1. The frame composed of the hollow columns *B* and *B'*, the pipes *C* and *C'*, having inlet and outlet pipes *m* and *n*, and the rods *a*, provided with screw-threads and nuts upon their ends, substantially as and for the purpose set forth.

2. The hollow columns *E*, in combination with the pipes *C*, caps *E'*, and bearing-plate *G*, provided with the lugs *b* and temper-screws for changing the position of the column upon the pipe, as specified.

3. The journal-boxes *F*, constructed as described, in combination with the columns *E*, and intervening elastic material, substantially as and for the purpose specified.

4. The grooved bed-plate *I*, the journal-boxes *H'* and *H''*, in combination with the pipes *C*, as specified.

5. The movable journal-boxes *P*, in combination with the springs *k* and collars *i* and pipes *C*, as set forth.

6. The movable journal-boxes *P*, in combination with the rods *h*, reciprocated by eccentrics or equivalent devices, and operated by the hand-lever *R*, substantially as specified.

7. The friction-pulley *O*, consisting of the side pieces *A* and the sectional plates *A'*, constructed and connected in the manner and for the purpose specified.

8. In combination with the pulley *O*, constructed as shown, the friction-wheels *L'* and *K*, their wearing-surfaces being formed of pasteboard in the manner described, and for the purpose set forth.

9. The flanged column *S*, carrying the saw-guides, in combination with the pipe *C* and stiffening-bar *b''*, as set forth.

10. The guides *o* and *p*, provided with the jaws *j* and *j'*, for holding the material which forms the saw-guides, constructed and operating in the manner set forth.

11. The bearing-roll *U*, provided with a splitting-wheel, *V*, in combination with the hooded journal-boxes *T* and *T'*, as and for the purpose specified.

12. The bearing-roll *U*, supported in the adjustable frame, as herein shown and described, in combination with the adjusting device *V'*, as and for the purpose specified.

13. The recessed pulley *J*, arranged with relation to the main driving-pulley *D''*, and driving-belt, as and for the purpose specified.

14. A machine composed of the various mechanisms herein shown and described, all the parts being constructed, combined, and arranged in the manner and for the purpose set forth.

In testimony that I claim the foregoing I have hereunto set my hand this 3d day of February, 1874.

ALEXANDER RODGERS.

Witnesses:

JOHN T. HOLMES,
JOHN GRAHAM.